

# Multivariable Adaptive Output-Feedback Regulation Using Adaptive Observer

Mohammad Hosein Kazemi <sup>1</sup>

Received 06/03/2016: Accepted: 08/06/2016

## Abstract

In this paper, an innovative adaptive output feedback control scheme is proposed for general multi-input multi-output (MIMO) plants with unknown parameters in a regulation task; such that the outputs of the plant converge to zero as well as the control gains remain uniformly bounded. First an adaptive observer is designed to estimate the state variables and system parameters by using the inputs and outputs of the plant. Then a linear combination of the estimated states by adaptive control gains is used to design a robust adaptive controller. Some theorems are given to show the convergence of the modeling errors and the control gains. The proposed controller is used to control a two degree of freedom robot manipulator such that the robot moves from any initial configuration to zero position. Simulation results exhibit the effectiveness of the proposed scheme to control the robot manipulator with different initial conditions and parameter perturbations.

**Keywords:** Adaptive observer; robust adaptive control; multivariable control; robot manipulator control;

## 1. Introduction

The extension of single-input single-output adaptive control algorithms to multivariable systems has been considered by several authors [4, 11, 17, 19]. An indirect adaptive interval type-2 fuzzy controller by using fuzzy descriptions to model the plant is proposed in [11] to handle the training data corrupted by noise or rule uncertainties. State feedback output tracking design for MIMO systems, using a less restrictive matching condition is employed in [18] and a simple controller structure is offered. High-frequency gain matrix decompositions, commonly used with output tracking designs, are presented in [7]. In [16], the design of adaptive controller for autonomous and non-autonomous control of a

nonlinear system using delta models is described based on a matrix approach and polynomial theory. An output-feedback adaptive dynamic surface control scheme is proposed for linear time-invariant multivariable plants based on the norm estimation of unknown parameter matrices in [21]. Later attempts were about various modifications such as  $\sigma$ -modification [6],  $\sigma_2$  modification [14] for robust adaptive control strategy. Since adaptive control is an appropriate method to control the plants where involving different set points, different operating points, and parameter variations, a two degree of freedom robot manipulator is chosen to demonstrate the effectiveness of the proposed method in this paper.

The simplest adaptive approach is gain scheduling, where the control parameters are set with respect to the selected work space region and load condition. The main disadvantage of such approach is a time-consuming determination of the adequate work space schedule for the complete work space range. Direct model reference adaptive methods do not show these disadvantages; their design and the design of the belonging adaptation mechanism is based on assuring the stability of a complete adaptive system. Because of inherent nature of the moving paths and loads, the operating points of a robot manipulator will be varied as a nonlinear manner during a moving cycle. Therefore, various schemes based on adaptive control theory have been proposed to deal with large parameter variations, such as inverse dynamics control [2, 20], sliding mode control [12, 22], Fuzzy logic theory [1, 10, 13] and robust adaptive control [3, 5]. The main objective of these control strategies is to extend the margins of the regions of stability and therefore to satisfy the increasingly complex control requirements in robot manipulators. From a control strategy point of view, the extension of single-input, single-output robust adaptive control algorithms to multivariable and large-scale systems has been considered by several authors [4, 19]. In [9] an adaptive robust output-feedback control strategy has been proposed for multivariable systems and it is used in multi-area power system in [8].

In this paper we introduce an adaptive control scheme based on an adaptive observer to estimate the set of state variables and parameters of a general MIMO plant. The main objective of

1. \*Shahe University, Iran. Electrical Engineering Department.

proposed control is to regulate the outputs of the plant. A linear combination of the estimated states with adjustable gains is fed back as a stable robust adaptive control signal such that the outputs of the plant asymptotically converge to zero.

The remainder of this paper is organized as follows. A full description of the problem statement is presented in Section 2. Section 3 presents the proposed adaptive control structure consist of adaptive observer and adaptive controller. Simulation results are demonstrated in Section 4. Finally, the conclusions are given in Section 5.

## 2. Problem Statement

Consider the MIMO plant under consideration with the following state space form,

$$\begin{aligned} \dot{\mathbf{x}}_p &= A_p \mathbf{x}_p + B_p u, \\ y &= C_p \mathbf{x}_p, \end{aligned} \quad (1)$$

where  $\mathbf{x}_p \in R^n$ ,  $u \in R^p$  and  $y \in R^m$  are the state vector, control input vector and output vector, respectively. The matrices  $A_p \in R^{n \times n}$ ,  $B_p \in R^{n \times p}$  and  $C_p \in R^{m \times n}$  with unknown elements describe the dynamics of the plant. Here without loss of generality, we consider  $q = m$ , and assume that the pair  $(A_p, B_p)$  is controllable, and the pair  $(C_p, A_p)$  is observable. Since the plant is assumed to be completely observable, it can be transformed to:

$$\begin{aligned} \dot{\mathbf{x}} &= (A + GC)\mathbf{x} + Bu, \\ y &= C\mathbf{x}, \end{aligned} \quad (2)$$

where,  $A$ ,  $B$ , and  $C$  are constant matrices with appropriate dimensions,  $(A, B)$  is controllable, and  $(C, A)$  is an arbitrary known observable pair, such as observable canonical form. Now, the on-line parameter identification problem is to estimate the unknown matrices  $B$  and  $G$  from the input and output data and to generate also  $\hat{x}$  as estimation of  $x$ . The main objective is to design a robust adaptive output feedback control for the plant (2) such that the outputs of the plant,  $y$ , converge to zero. The first part of the proposed control strategy is to construct an adaptive observer, which estimates the state vector  $\hat{x}$  and system parameters ( $B$  and  $G$ ) from input and

output data. This is discussed in the following section.

Considering the plant (2), the first stage in developing the proper controller is aimed at constructing an adaptive observer so that the unknown matrices  $B$  and  $G$ , as well as the state vector  $x$  are estimated asymptotically. Knowing that  $(C, A)$  is observable, we may find an  $n \times m$  matrix  $G_0$  so that the  $A + G_0 C$  is asymptotically stable. This leads to rewrite (2) as:

$$\begin{aligned} \dot{\mathbf{x}} &= (A + G_0 C)\mathbf{x} + (G - G_0)C\mathbf{x} + Bu, \\ y &= C\mathbf{x}. \end{aligned} \quad (3)$$

An adaptive observer can then be introduced as:

$$\begin{aligned} \dot{\hat{\mathbf{x}}} &= (A + G_0 C)\hat{\mathbf{x}} + (\hat{G} - G_0)y + \hat{B}u + v, \\ \hat{y} &= C\hat{\mathbf{x}}, \end{aligned} \quad (4)$$

where  $\hat{x}$  is the estimate of the states,  $\hat{G}$  and  $\hat{B}$  are the estimates of the parameters  $B$  and  $G$  respectively and  $v$  is an auxiliary signal that must be chosen so that the stability of the estimation is ensured.

## 3. Observer and Controller Adaptive Laws

This section, at first introduces an adaptive law for the adaptive observer (4), and then proposes the control law with its appropriate adaptive law, as depicted in *Figure 1*.

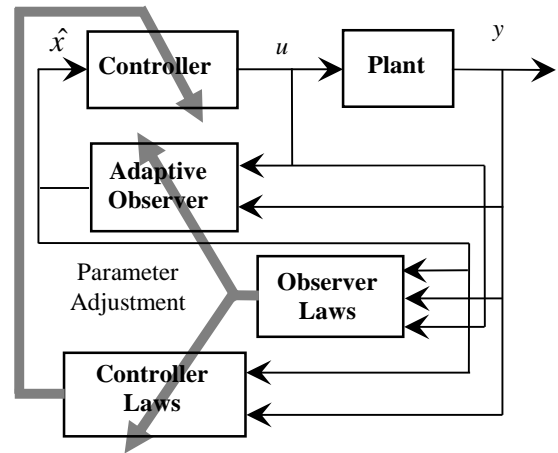

Figure 1. Proposed adaptive control structure.

From (3) and (4), the state estimation error equation is described by

$$\begin{aligned} \dot{\mathbf{e}} &= (A + G_0 C)\mathbf{e} + (\hat{G} - G)y + (\hat{B} - B)u + v, \\ e_1 &= C\mathbf{e}, \end{aligned} \quad (5)$$

where  $e := \hat{x} - x$ , and  $e_1 := \hat{y} - y$ . Denote,  $j := \hat{G} - G$ ,  $y := \hat{B} - B$ , and rewrite (5) as:

$$\dot{\mathbf{e}} = (A + G_0 C)e + \begin{bmatrix} y & j \end{bmatrix} \begin{bmatrix} u \\ y \end{bmatrix} + v, \quad (6)$$

$$e_1 = Ce,$$

It can be shown that the given error equation (6), together with the adaptive law [8],

$$\dot{\mathbf{K}} = -X^T C^T (\hat{y} - y), \quad (7)$$

and the auxiliary signal  $v = X \mathbf{K}$  results in the uniform stability and  $\lim_{t \rightarrow \infty} e_1 = 0$  as well, where  $\mathbf{1} = \text{Vec}([\hat{B}, \hat{G}])$ . The  $\text{Vec}(M)$ , denotes the vector formed by stacking the columns of  $M$  into one long vector, and the matrix  $X$  consists of  $m$  matrices  $X : R^+ \rightarrow R^{n \times n}$  as:

$$\begin{aligned} X &= [X_1, X_2, \mathbf{1}, X_{2m}], \\ \dot{X}_i &= (A + G_0 C)X_i + Iu_i, \\ \dot{X}_{i+m} &= (A + G_0 C)X_{i+m} + Iy_i \end{aligned}, i=1, \dots, m, \quad (8)$$

and  $I$  is an identity matrix of size  $n$ . If, in addition,  $u_i$  is persistently exciting with sufficient number of frequencies [15], it can be also shown that  $j$ ,  $y$ , and therefore  $e$  tends to zero asymptotically.

The next stage of the proposed controller consists of designing a robust adaptive output feedback control so that the outputs,  $y$ , converge to zero asymptotically. The following control law is proposed to meet this control objective.

$$u = K^* \hat{x}, \quad (9)$$

where  $K^* \in R^{m \times n}$  is the feedback gain, and  $\hat{x}$  is the estimated state vector which is constructed from the adaptive observer (4). By adding and subtracting the term  $BK^*x$ , in the plant equation (2), and using the control law (9), we obtain

$$\dot{\mathbf{e}} = (A + GC + BK^*)x + BK^*e. \quad (10)$$

Hence, if  $K^*$  is chosen to satisfy the algebraic equation

$$A + GC + BK^* = A_m, \quad (11)$$

where,  $A_m \in R^{n \times n}$  is a desired stable matrix, then by knowing that  $e \rightarrow 0$  exponentially fast, we can conclude that the transfer matrix of the closed-loop plant is the same as that of the reference model  $x \rightarrow 0$  exponentially. We should note that

in general, no  $K^*$  may exist to satisfy the matching condition (11) for the given matrices  $A$ ,  $B$ ,  $G$ ,  $C$ ,  $A_m$ , indicating that the control law (9) may not have enough structural flexibility to meet the control objective. But if the structure of those matrices are known, then  $A_m$  may be designed so that (11) has a solution for  $K^*$ . By this assumption, we can propose the control law

$$u = K(t)\hat{x}, \quad (12)$$

where  $K(t)$  is the estimate of  $K^*$ , to be generated by an appropriate adaptive law.

By adding and subtracting the term,  $BK^*e$  in the plant equation (2), using control law (12), and matching condition (11), we obtain

$$\begin{aligned} \dot{\mathbf{e}} &= A_m x + BK^*e + BK^*e, \\ y &= Cx, \end{aligned} \quad (13)$$

where  $\mathbf{K}^0 := K - K^*$  is the controller parameter error.

It can be shown that, the error equation (13) and the following error system have the same outputs as  $t \rightarrow 0$ , [9].

#### Theorem 1

The matrices  $D \in R^{n \times m}$ , and  $Y : R^+ \rightarrow R^{n \times n^2}$ , can be determined so that the system equation (13) follows asymptotically the error system

$$\begin{aligned} \dot{\mathbf{e}} &= A_m e + DCYB_d \mathbf{K}^0 - YB_d \mathbf{K}^0, \\ e_1 &= Ce, \end{aligned} \quad (14)$$

where,  $\mathbf{K}^0 = \text{Vec}(\mathbf{K}^0)$ ,  $B_d = I_n \otimes B$ , and  $\otimes$  denotes the Kronecker product, and the matrix  $Y$  consist of  $n$  matrices  $Y_i : R^+ \rightarrow R^{n \times n}$  such that:

$$\begin{aligned} \dot{Y}_i &= A_m Y_i + Ix_i, i=1, \dots, n, \\ Y &= [Y_1, Y_2, \mathbf{1}, Y_n]. \end{aligned} \quad (15)$$

#### Proof

The following lemma is first stated.

Lemma 1 [15]

Let  $Z(s)$  be a matrix of rational functions such that  $Z(\infty) = 0$  and  $Z(s)$  has poles only in  $\text{Re}[s] < -m$ , ( $m > 0$ ). Let  $(C, A, B)$  be a minimal realization of  $Z(s)$ . Then,  $Z(s)$  is Strictly Positive Real (SPR) if and only if there exist a symmetric positive-definite matrix  $P$  and a matrix  $L$  such that:

$$\begin{aligned} A^T P + PA &= -LL^T - 2mP = -Q, \\ PB &= C^T. \end{aligned} \tag{16}$$

Now we may proceed the proof of the theorem 1. The equation (13) can be rewritten as:

$$\dot{x} = A_m x + BK^* e + \sum_{i=1}^n j_i \hat{x}_i, \tag{17}$$

where,  $j_i$  's are the column vectors of matrix  $j := BK^*$ , and  $\hat{x}_i$  's are elements of  $\hat{x}$ . Using (15) into (17) we can obtain

$$\dot{x} = A_m x + BK^* e + \sum_{i=1}^n \left\{ \frac{d}{dt} (Y_j j_i) - A_m Y_j j_i - Y_j \dot{j} \right\}. \tag{18}$$

Since  $(C, A_m)$  is observable, there exists a matrix  $D$  so that  $A_m + DC$  is asymptotically stable and we may choose  $D$  so that the system  $(C, A_m, D)$  is SPR. By defining

$$h := BK^* e + \sum_{i=1}^n \left\{ \frac{d}{dt} (Y_j j_i) - (A_m + DC)(Y_j j_i) \right\}, \tag{19}$$

Equation (18) will be reduced to

$$\dot{x} = A_m x + h + DCYB_d \dot{y} - YB_d \dot{y}. \tag{20}$$

Now, we introduce the Lyapunov function  $V = x_i^T P x_i$  for the system

$$\dot{x}_i = (A_m + DC)x_i + r_i, \tag{21}$$

where,  $x_i = Y_j j_i$  and  $P$  is the positive definite symmetric matrix obtained from Lemma 1. Evaluating the time derivative of  $V$  along the trajectory of the system (21), and using Lemma 1, imply that

$$\begin{aligned} \dot{V} &= -x_i^T LL^T x_i \\ &\quad + 2(x_i^T P r_i - m x_i^T L x_i + x_i^T C^T C x_i). \end{aligned} \tag{22}$$

Now  $m$  is chosen sufficiently large such that

$$(x_i^T P r_i - m x_i^T L x_i + x_i^T C^T C x_i) < 0, \tag{23}$$

then  $\dot{V}$  becomes negative; this implies the boundedness of  $r_i$ . Substituting  $r_i$  from (21) into (19), we obtain

$$h = BK^* e + \sum_{i=1}^n r_i. \tag{24}$$

Knowing that,  $e = \hat{x} - x$  is the state estimation error of the adaptive observer, (5), where its boundedness is established, concludes that  $h$  is

bounded. Define  $g := x - e$ , and subtracting (14) from (20), imply

$$\dot{g} = A_m g + h. \tag{25}$$

Since  $A_m$  is a stable matrix, according to the input-output stability theorems[15], boundedness of  $h$  results in the convergence of  $Cg$  to zero asymptotically. In other words  $y$  tends to  $e_1$  as  $t \rightarrow \infty$ .

Now we may use the next theorem to obtain the adaptive laws.

Theorem 2

The origin of the error system (14) and the following adaptive law

$$\dot{k} = -B_d^T Y^T C^T e_1, \tag{26}$$

is uniformly stable in the large.

**Proof**

Considering the following Lyapunov function

$$V = e^T P e + k^T k, \tag{27}$$

and evaluating  $\dot{V}$  along (14) and (26), and using the result of Lemma 1, it follows that

$$\dot{V} = -e^T LL^T e - 2e^T (mP - PYB_d B_d^T Y^T C^T C) e. \tag{28}$$

Obviously choosing  $m$  sufficiently large such that  $mP - PYB_d B_d^T Y^T C^T C > 0$ , result in  $\dot{V} < 0$ , and therefore uniformly stability of the origin of (14) and (26).

Since  $e_1$  tends to  $y$  asymptotically, the adaptive law

$$\dot{k} = -B_d^T Y^T C^T y, \tag{29}$$

can be practically used to stabilize the origin of the system (13). The only remaining problem is that the matrix  $B_d$  is unknown, and therefore the adaptive law (29) is not applicable. To solve this problem, we can use the estimate of  $B_d$ , i.e.,  $\hat{B}_d$  as

$$\hat{B}_d = I_n \otimes \hat{B}. \tag{30}$$

However, such substitution may make some errors in the convergence of the overall system.

To avoid that, a robust adaptive law is proposed as following theorem.

Theorem 3

The error system (14) with the adaptive law

$$\dot{k} = -\hat{B}_d^T Y^T C^T e_1 - s k, \quad (31)$$

where,

$$s = \begin{cases} s_0 \|e_1\| & \text{if } \|e_1\| \geq K_0 \\ 0 & \text{if } \|e_1\| < K_0 \end{cases}, \quad (32)$$

$k = \text{Vec}(K)$ ,  $K_0, s_0$  are design constants satisfying  $K_0 > \|k^*\|$  and  $s_0 > 0$ ,  $k^* = \text{Vec}(K^*)$ ; converges to the residual set

$$R_s = \left\{ (e, k) \mid I_{\min}(LL^T) \|e\|^2 + s \|k\|^2 < s \|k^*\|^2 + 2k^*(B_d - \hat{B}_d)^T Y^T C^T C e \right\} \quad (33)$$

**Proof**

Considering the Lyapunov function (27), and evaluating  $\dot{V}$  along (14) and (32), and using the result of Lemma 1, it follows that

$$\begin{aligned} \dot{V} &= -e^T LL^T e - 2s k^T k \\ &\quad + 2k^*(B_d - \hat{B}_d)^T Y^T C^T C e - 2m e^T P e \\ &\quad + 2e^T P Y B_d \hat{B}_d^T Y^T C^T C e + 2s e^T P Y B_d k. \end{aligned} \quad (34)$$

The following inequality is easily established for the three last terms of above equation

$$\begin{aligned} -2m e^T P e + 2e^T P Y B_d \hat{B}_d^T Y^T C^T C e \\ + 2s e^T P Y B_d k &\leq -2 \left[ -\|P Y B_d \hat{B}_d^T Y^T C^T C\| \right. \\ &\quad \left. + m I_{\min}(P) - s_0 \|P Y B_d k\| \|C\| \right] \|e\|^2. \end{aligned} \quad (35)$$

By choosing  $m$  sufficiently large so that the right hand side of the inequality (35) becomes negative, the following inequality is obtained.

$$\dot{V} \leq -e^T LL^T e - 2s k^T k + 2k^*(B_d - \hat{B}_d)^T Y^T C^T C e \quad (36)$$

Using inequality  $-2k^* k \leq -k^* k + k^{*T} k^*$  in (36), we have

$$\dot{V} \leq -e^T LL^T e + 2k^*(B_d - \hat{B}_d)^T Y^T C^T C e - s k^* k + s k^{*T} k^*. \quad (37)$$

This implies that the error system (14) with the adaptive law (31) converges to the residual set (33).

#### 4. Simulation Results

In this section, the proposed adaptive regulation scheme is applied to a two-link planar rotary robot manipulator, shown in **Figure 2**. The control objective is to move the robot from the any initial condition to the vertical position  $q_1 = q_2 = 0$ .

Through the Euler-Lagrangian approach, its dynamic equation is derived as compact form:

$$D(q)\ddot{q} + C(\dot{q}, q) + G(q) = t \quad (38)$$

where,

$$q = \begin{bmatrix} q_1 \\ q_2 \end{bmatrix}, \quad t = \begin{bmatrix} t_1 \\ t_2 \end{bmatrix},$$

$$D_{11}(q) = (M_1 + M_2)L_1^2 + M_2L_2^2 + 2M_2L_1L_2 \cos q_2,$$

$$D_{12}(q) = D_{21}(q) = M_2L_2^2 + M_2L_1L_2 \cos q_2,$$

$$D_{22}(q) = M_2L_2^2,$$

$$C(\dot{q}, q) = \begin{bmatrix} -M_2L_1L_2(2\dot{q}_1\dot{q}_2 + \dot{q}_2^2) \sin q_2 \\ M_2L_1L_2\dot{q}_1 \sin q_2 \end{bmatrix},$$

$$G(q) = \begin{bmatrix} -(M_1 + M_2)L_1g \sin q_1 - M_2L_2g \sin(q_1 + q_2) \\ -M_2L_2g \sin(q_1 + q_2) \end{bmatrix},$$

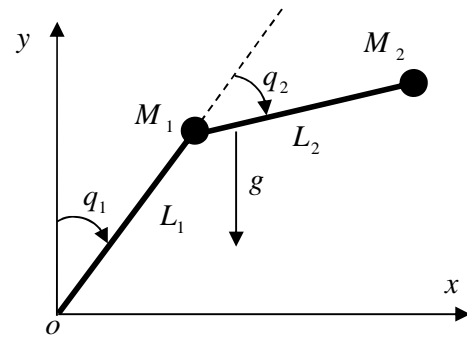

**Figure 2.** Two-link planar rotary robot manipulator.

The physical parameters of the robot manipulator are defined as follows:  $L_1 = L_2 = 1(\text{m})$ ,  $M_1 = M_2 = 1(\text{kg})$ . According to the proposed method we should first consider the linear dynamic equation (2) for the system with unknown parameters  $G$  and  $B$ , and known observable pair  $(C, A)$  which is chosen by

designer. In this implementation, the parameters  $A$  and  $C$  are selected as follows:

$$A = \begin{bmatrix} 0 & 1 & 0 & 0 \\ -1 & -4 & 0 & 0 \\ 0 & 0 & 0 & 1 \\ 0 & 0 & -1 & -4 \end{bmatrix}, C = \begin{bmatrix} 1 & 0 & 0 & 0 \\ 0 & 0 & 1 & 0 \end{bmatrix}$$

By constructing the adaptive observer (4) with the adaptive law (7), and selecting the matrix  $G_0$  to assign the eigenvalues  $\{-3, -4, -5, -6\}$  to  $A + G_0C$ , the estimated states  $\hat{x}$  will be generated for using in control law (12). Now we can implement the control law (12) with the adaptive law (31) to put the manipulator in the vertical position. We start up the proposed control scheme by choosing random initial conditions for the observer adaptive law (7) and the control adaptive law (31). **Figure 3** shows the parameter and control convergence trends. As we can see in the figure, the estimations of the parameters and control gains have reached to constant values at less than 140 seconds. The joint angles deviations are also shown in **Figure 4**. It should be noted that this does not mean that the estimation of the parameters or control gains are converged to their true values, because for this purpose it is needed that the control signal to be sufficiently reach at some frequencies to satisfy the persistent excitation condition. Beside, because of the nonlinearity of the system there are not any fixed values for the system parameters except in the goal position, i.e., vertical position of the manipulator. However, from control pint of view the only important subject is the convergence of the error signal to zero that is achieved as shown in the simulation results. **Figure 5** shows the response of the robot manipulator to the proposed control with the initial condition  $q_1 = \pi/4, q_2 = -\pi/4$ . The response of the robot manipulator for the initial condition  $q_1 = -\pi/3, q_2 = \pi/6$  is also depicted in the **Figure 6**. In this case the control actions are shown in the **Figure 7**. It is obvious that the control signals or the manipulator joint torques have satisfactory deviations. For investigating the robustness of the proposed method against the manipulator parameters variations, we have made a parameter perturbation about 30% on the lengths and masses of the robot manipulator. **Figure 8** shows the manipulator joint angles with  $L_1=0.7(m)$ ,

$L_2=1.3(m)$ ,  $M_1=1.3(kg)$ , and  $M_2=0.7(kg)$ . As we can see in the simulation results, the control objective is completely met by the proposed control scheme, and manipulator joint angles converge to zero fast from any initial condition and have an acceptable robust performance.

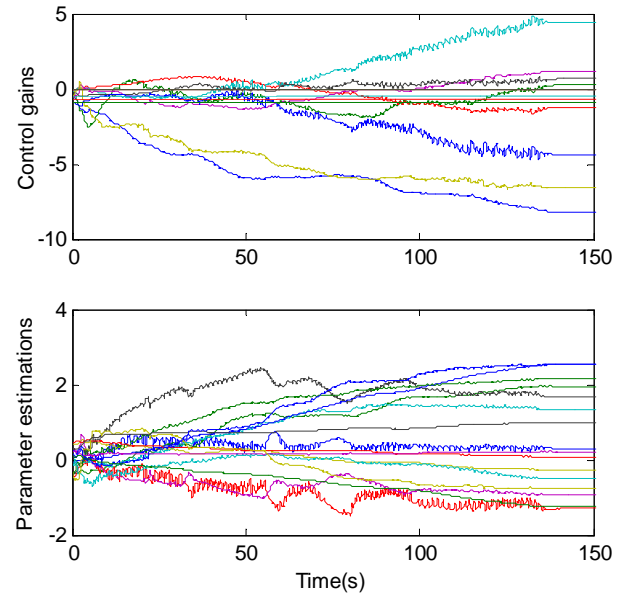

**Figure 3.** Convergence trend of estimated parameters and control gains when the proposed control is started up with random initial conditions.

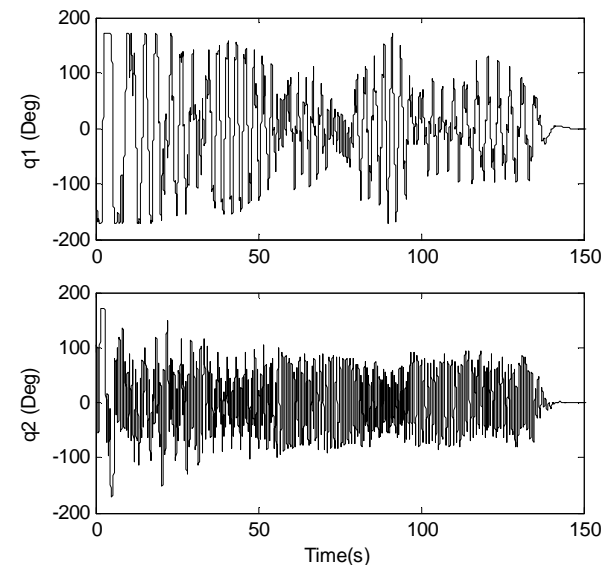

**Figure 4.** Joint angles deviation when the proposed control is started up with random initial conditions.

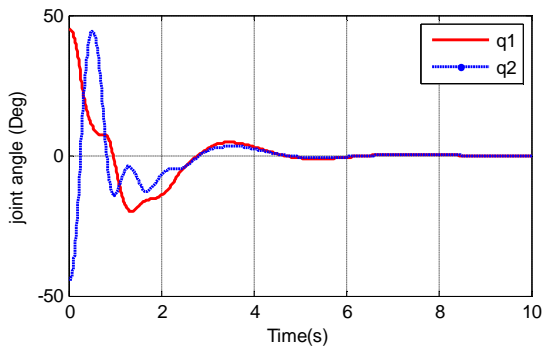

**Figure 5.** Joint angles deviation from initial position  $q_1 = \frac{\pi}{4}, q_2 = -\frac{\pi}{4}$ .

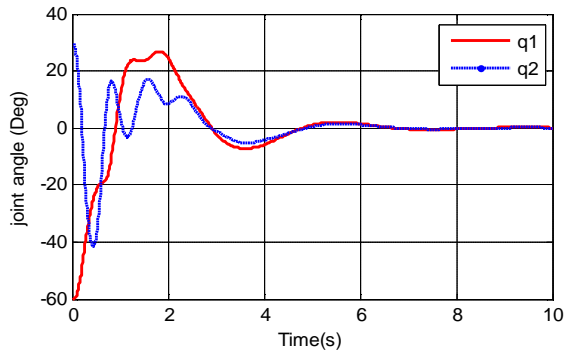

**Figure 6.** Joint angles deviation from initial position  $q_1 = -\frac{\pi}{3}, q_2 = \frac{\pi}{6}$ .

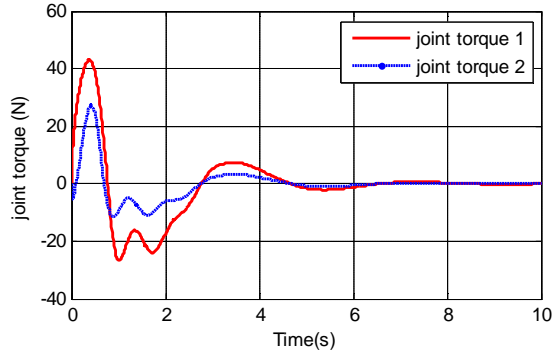

**Figure 7.** Manipulator joint torques for initial position  $q_1 = -\frac{\pi}{3}, q_2 = \frac{\pi}{6}$ .

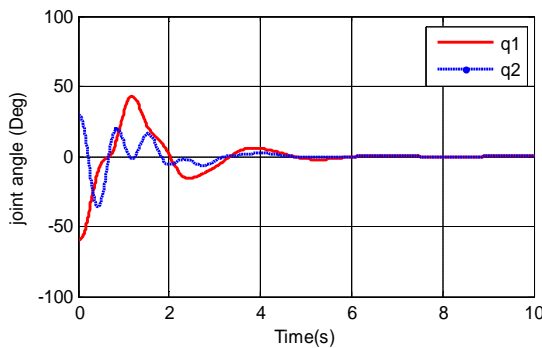

**Figure 8.** Joint angles deviation for 30 percent perturbation on robot parameters.

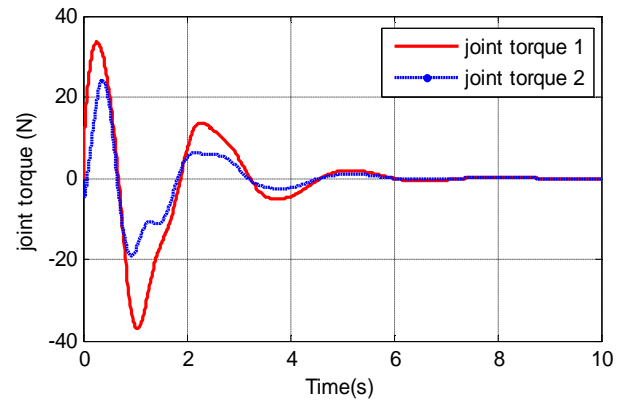

**Figure 9.** Manipulator joint torques for 30 percent perturbation on robot parameters.

### 5. Conclusions

This paper described a robust adaptive regulator based on designing an adaptive observer for general multivariable systems. As evidenced by fundamental theoretical results on the convergence of system outputs to zero, this framework successfully presented the utilization of a multivariable adaptive observer in an adaptive control structure to regulate the outputs of wide class of MIMO systems. With the introduction of an estimated state feedback control law, and an innovative adaptation laws, the proposed controller was able to compensate the nonlinearity and uncertainties in the dynamic model. The successful design of the adaptive control architecture relied on a key selection of the observable pair  $(C, A)$  in adaptive observer design stage. Although Theorem 3 had implied convergence of the error signals to a residual set without any further assumption on the observable pair  $(C, A)$ , but it should be noted that the inappropriate choosing of the pair  $(C, A)$  may obviously affects the convergence duration of the parameters estimation and control gains adaptation in start-up stage of control implementation.

Numerical simulation was used to illustrate the control of a regulation task imposed on a two-degree-of-freedom robot arm with unknown kinematics parameters. The results demonstrated desirable regulation performance and smooth control input even with a large percentage of parameter perturbation.

## 6. References

- [1] Y. Chen, G. Y. Ma, S. X. Lin, and J. Gao, "Adaptive fuzzy computed-torque control for robot manipulator with uncertain dynamics," *International Journal of Advanced Robotic Systems*, vol. 9, pp. 201-209, 2012.
- [2] Y. Chen, G. Mei, G. M. S. Lin, and J. Gao, "Robust adaptive inverse dynamics control for uncertain robot manipulator," *International Journal of Innovative Computing, Information and Control*, vol. 10, pp. 575-587, 2014.
- [3] H. B. Dou and S. P. Wang, "Robust adaptive motion/force control for motion synchronization of multiple uncertain two-link manipulators," *Mechanism and Machine Theory*, vol. 67, pp. 77-93, 2013.
- [4] L. Dugard, G. C. Goodwin, and C. E. D. Souza, "Prior knowledge in model reference adaptive control of multi-input multi-output systems," *IEEE Trans. Automat. Contr.*, vol. 29, pp. 761-764, 1984.
- [5] H. Ge, Z. L. Jing, and J. Gao, "Neural network H-infinity robust adaptive control for autonomous underwater vehicle in 3-dimensional path following," *Control Theory and Applications*, vol. 29, pp. 317-322, 2012.
- [6] P. A. Ioannou, "Decentralized adaptive control of interconnected systems," *IEEE Trans. Automat. Contr.*, vol. AC-31, pp. 291-298, 1986.
- [7] G. T. J. Guo and Y. Liu, "A multivariable MRAC scheme with application to a nonlinear aircraft model," *Automatica*, vol. 47, pp. 804-812, 2011.
- [8] M. H. Kazemi, M. Karrari, and M. B. Menhaj, "Decentralized robust adaptive output-feedback controller for power systems load frequency control," *ELECTRICAL ENGINEERING*, vol. 48, 2002.
- [9] M. H. Kazemi, M. Karrari, and M. B. Menhaj, "Multivariable adaptive output-feedback control," presented at the American Control Conference, Anchorage, AK, 2002.
- [10] Y. M. Li, S. C. Tong, and T. S. Li, "Adaptive fuzzy output feedback control for a single-link flexible robot manipulator driven DC motor via backstepping," *Nonlinear Analysis: Real World Applications*, vol. 14, pp. 483-494, 2013.
- [11] T. C. Lin, M. J. Kuo, and C. H. Hsu, "Robust adaptive tracking control of multivariable nonlinear systems based on interval type-2 fuzzy approach," *International Journal of Innovative Computing, Information and Control*, vol. 6, 2010.
- [12] Z. H. Man, X. H. Yu, K. Eshraghian, and M. Palaniswami, "A robust adaptive sliding mode tracking control using an RBF neural network for robotic manipulators," presented at the IEEE International Conference on Neural Networks, Perth, Australia, 1995.
- [13] S. Mohan and S. Bhanot, "Comparative study of some new hybrid fuzzy algorithms for manipulator control," *Journal of Control Science and Engineering*, vol. 2007, pp. 1-10, 2007.
- [14] K. S. Narendra and A. M. Annaswamy, "A new adaptive law for robust adaptation without persistent excitation," *IEEE Trans. Automat. Contr.*, vol. AC-32, pp. 134-145, 1987.
- [15] K. S. Narendra and A. M. Annaswamy, *Stable Adaptive Systems*. Englewood Cliffs, New Jersey: Prentice-Hall, 1989.
- [16] P. Navratil, "A multivariable adaptive control design with applications to air-heat tunnel using delta models," *American Journal of Mechanical Engineering*, vol. 1, pp. 293-299, 2013.
- [17] E. A. Parsheva, "Adaptive decentralized control of multivariable plants with scalar input and output and nonminimal realization of the reference model," *Automation and Remote Control*, vol. 66, pp. 1296-1304, 2005.
- [18] J. M. Selfridge and G. Tao, "A multivariable adaptive controller for a quadrotor with guaranteed matching conditions," *Systems Science & Control Engineering*, vol. 2, pp. 24-33, 2014.
- [19] X. Sun and M. Rao, "A multivariable bilinear adaptive controller with decoupling design," *IEEE Trans. Automat. Contr.*, vol. 45, 2000.
- [20] H. L. Wang, "On adaptive inverse dynamics for free-floating space manipulators," *Robotics and Autonomous Systems*, vol. 59, pp. 782-788, 2011.
- [21] C. Wanga and Y. Lina, "Multivariable adaptive dynamic surface control based on norm estimation of unknown parameter matrices," *International Journal of Control*, vol. 85, pp. 1827-1837, 2012.
- [22] J. J. Wu, K. Liu, and D. P. Han, "Adaptive sliding mode control for six-DOF relative motion of spacecraft with input constraint," *Acta Astronautica*, vol. 87, pp. 64-76, 2013.